

RACAL INSTRUMENTS
1260-16A
64 CHANNEL, 6A HIGH POWER
SWITCH MODULE

PUBLICATION NO. 980673-064

EADS North America Defense Test and Services, Inc.
4 Goodyear, Irvine, CA 92618
Tel: (800) 722-2528, (949) 859-8999; Fax: (949) 859-7139

info@eads-nadefense.com
sales@eads-nadefense.com
helpdesk@eads-nadefense.com
<http://www.eads-nadefense.com>



PUBLICATION DATE: September 07, 2005

Copyright 2005 by EADS North America Defense Test and Services, Inc. Printed in the United States of America. All rights reserved. This book or parts thereof may not be reproduced in any form without written permission of the publisher.

**THANK YOU FOR PURCHASING THIS
EADS NORTH AMERICA DEFENSE TEST AND SERVICES PRODUCT**

For this product, or any other EADS North America Defense Test and Services, Inc. product that incorporates software drivers, you may access our web site to verify and/or download the latest driver versions. The web address for driver downloads is:

<http://www.eads-nadefense.com/downloads>

If you have any questions about software driver downloads or our privacy policy, please contact us at

info@eads-nadefense.com

WARRANTY STATEMENT

All EADS North America Defense Test and Services, Inc. products are designed and manufactured to exacting standards and in full conformance to EADS ISO 9001:2000 processes.

This warranty does not apply to defects resulting from any modification(s) of any product or part without EADS North America Defense Test and Services, Inc. express written consent, or misuse of any product or part. The warranty also does not apply to fuses, software, non-rechargeable batteries, damage from battery leakage, or problems arising from normal wear, such as mechanical relay life, or failure to follow instructions.

This warranty is in lieu of all other warranties, expressed or implied, including any implied warranty of merchantability or fitness for a particular use. The remedies provided herein are buyer's sole and exclusive remedies.

For the specific terms of your standard warranty, or optional extended warranty or service agreement, contact your EADS North America Defense Test and Services, Inc. customer service advisor. Please have the following information available to facilitate service.

1. Product serial number
2. Product model number
3. Your company and contact information

You may contact your customer service advisor by:

E-Mail:	Helpdesk@eads-nadefense.com	
Telephone:	+1 800 722 3262	(USA)
Fax:	+1 949 859 7309	(USA)

RETURN of PRODUCT

Authorization is required from EADS North America Defense Test and Services, Inc. before you send us your product for service or calibration. Call or contact the Customer Support Department at 1-800-722-3262 or 1-949-859-8999 or via fax at 1-949-859-7139. We can be reached at: helpdesk@eads-nadefense.com.

PROPRIETARY NOTICE

This document and the technical data herein disclosed, are proprietary to EADS North America Defense Test and Services, Inc., and shall not, without express written permission of EADS North America Defense Test and Services, Inc., be used, in whole or in part to solicit quotations from a competitive source or used for manufacture by anyone other than EADS North America Defense Test and Services, Inc. The information herein has been developed at private expense, and may only be used for operation and maintenance reference purposes or for purposes of engineering evaluation and incorporation into technical specifications and other documents which specify procurement of products from EADS North America Defense Test and Services, Inc.

DISCLAIMER

Buyer acknowledges and agrees that it is responsible for the operation of the goods purchased and should ensure that they are used properly and in accordance with this handbook and any other instructions provided by Seller. EADS North America Defense Test and Services, Inc. products are not specifically designed, manufactured or intended to be used as parts, assemblies or components in planning, construction, maintenance or operation of a nuclear facility, or in life support or safety critical applications in which the failure of the EADS North America Defense Test and Services, Inc. product could create a situation where personal injury or death could occur. Should Buyer purchase EADS North America Defense Test and Services, Inc. product for such unintended application, Buyer shall indemnify and hold EADS North America Defense Test and Services, Inc., its officers, employees, subsidiaries, affiliates and distributors harmless against all claims arising out of a claim for personal injury or death associated with such unintended use.

FOR YOUR SAFETY

Before undertaking any troubleshooting, maintenance or exploratory procedure, read carefully the **WARNINGS** and **CAUTION** notices.



CAUTION
RISK OF ELECTRICAL SHOCK
DO NOT OPEN



This equipment contains voltage hazardous to human life and safety, and is capable of inflicting personal injury.



If this instrument is to be powered from the AC line (mains) through an auto-transformer, ensure the common connector is connected to the neutral (earth pole) of the power supply.



Before operating the unit, ensure the conductor (green wire) is connected to the ground (earth) conductor of the power outlet. Do not use a two-conductor extension cord or a three-prong/two-prong adapter. This will defeat the protective feature of the third conductor in the power cord.



Maintenance and calibration procedures sometimes call for operation of the unit with power applied and protective covers removed. Read the procedures and heed warnings to avoid “live” circuit points.

Before operating this instrument:

1. Ensure the proper fuse is in place for the power source to operate.
2. Ensure all other devices connected to or in proximity to this instrument are properly grounded or connected to the protective third-wire earth ground.

If the instrument:

- fails to operate satisfactorily
- shows visible damage
- has been stored under unfavorable conditions
- has sustained stress

Do not operate until, performance is checked by qualified personnel.

Racal Instruments

CE Declaration of Conformity

We

Racal Instruments Inc.
4 Goodyear Street
Irvine, CA 92618

declare under sole responsibility that the

1260-16A, 64 1x2 10 MHZ MUXES, P/N 408012

conforms to the following Product Specifications:

EMC: EN61326: 1997 +A1: 1998 +A2: 2001 +A3: 2003 Class A

EN61000-3-2: 2000 +A2: 2005 Class A

EN61000-3-3: 1995 +A1: 2001

Supplementary Information:

The above specifications are met when the product is installed in a Racal Instruments certified mainframe with faceplates installed over all unused slots, as applicable

The product herewith complies with the requirements of the Low Voltage Directive 73/23/EEC and the EMC Directive 89/336/EEC (modified by 93/68/EEC).

Irvine, CA, May 20, 2006

VP of Engineering
Karen Evensen

This page was left intentionally blank.

Table of Contents

Chapter 1 1-1

SPECIFICATIONS 1-1

 Introduction 1-1

 Specifications 1-3

 Power Dissipation 1-4

 About MTBF 1-5

 Ordering Information 1-6

Chapter 2 2-1

INSTALLATION INSTRUCTIONS..... 2-1

 Unpacking and Inspection..... 2-1

 Reshipment Instructions..... 2-1

 Option 01T Installation 2-1

 Module Installation 2-2

 Module Configuration 2-2

 Front Panel Connectors..... 2-3

 Mating Connectors..... 2-7

 More About Maximum Current Ratings 2-8

 Installation 2-8

Chapter 3 3-1

MODULE OPERATION 3-1

 Operating Modes 3-1

 Operating In Message-Based Mode 3-3

 Channel Descriptors For 1260-16A 3-3

 Reply To The MOD:LIST? Command..... 3-4

 Operating The 1260-16A in Register-Based Mode 3-4

Chapter 4 4-1

PRODUCT SUPPORT 4-1

 Product Support 4-1

 Warranty 4-1

List of Figures

Figure 1-1, The 1260-16A..... 1-2

Figure 2-1, 1260-16A, Switch Block Diagram 2-3

Figure 2-2, Front Panel Connector Numbering..... 2-4

Figure 2-3, Front Panel Connector Pin Numbering..... 2-5

Figure 3-1, Message-Based Mode of Operation..... 3-1

Figure 3-2, Register-Based Mode of Operation 3-2

Figure 3-3, Relay Diagram..... 3-6

List of Tables

Table 2-1, 1260-16A Front-Panel Connections 2-6

Table 2-2, Mating Connectors and Pins..... 2-7

Table 3-1, Control Register Channel Assignments..... 3-6

Table 3-2, Status Register Channel Assignments 3-7

This page was left intentionally blank.

Chapter 1

SPECIFICATIONS

Introduction

The 1260-16A is a High Power VXI Switch Module developed for the 1260 Series of switch modules.

The 1260-16A is available configured from the factory and can be ordered with the Option-01T Message Based Interface.

The following features are included in the 1260-16A

- Message Based Interface Option available.
- Supports coil voltage Read Back to test coils are driven.
- Data-Driven embedded descriptor, allowing immediate use with any Option-01T switch controller, regardless of firmware revision level.

The 1260-16A Power Switching module provides 64 independent channels of SPDT switching. Each channel functions independently with all paths accessible through the front panel connectors. The module permits switching currents of up to 6 amps at 30 volts DC or 250 volts RMS per channel.

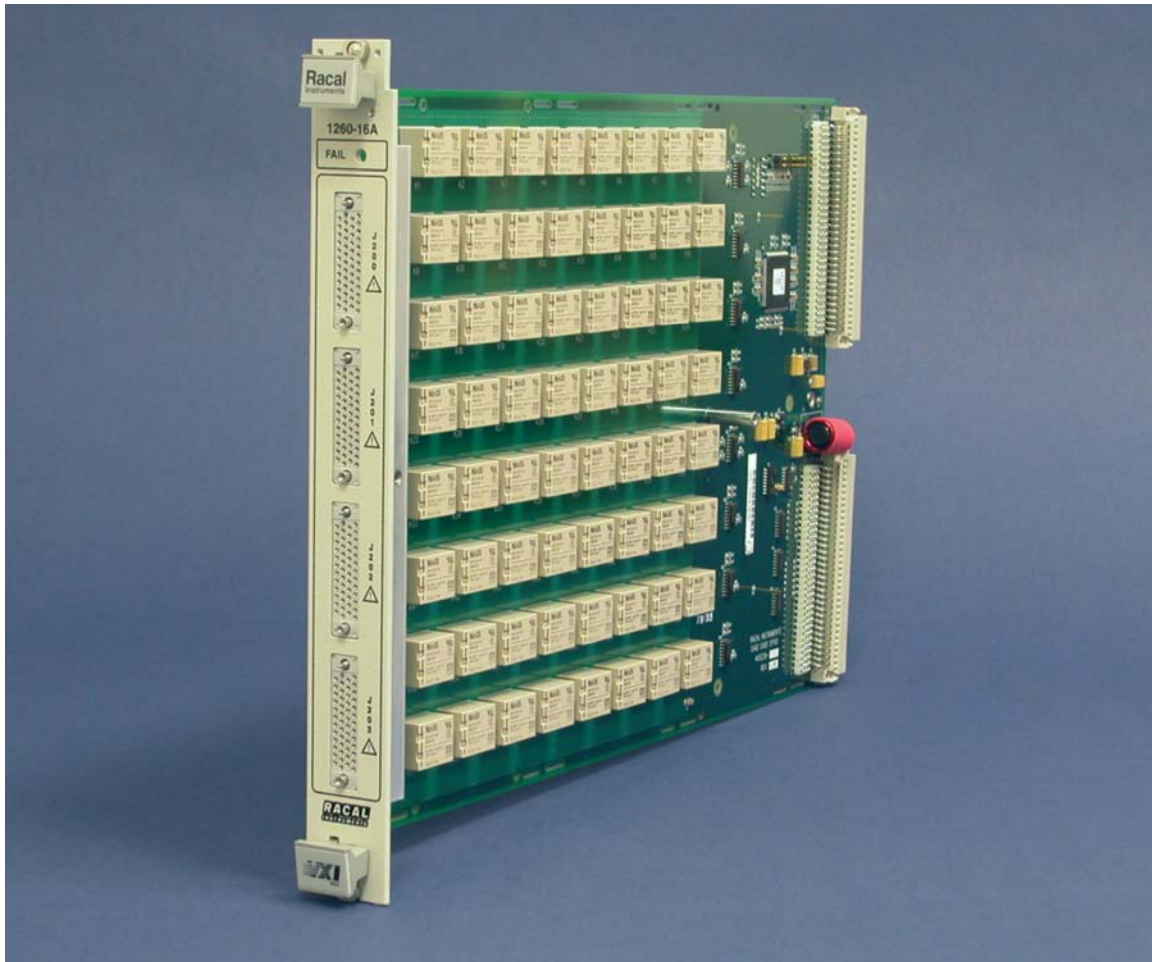

Figure 1-1, The 1260-16A

Specifications

Bandwidth (-3dB)	> 10MHz
Insertion Loss	
DC to 1 MHz	< 0.25 dB
DC to 10 MHz	< 2 dB
Channel Isolation	
DC to 1 MHz	> 45 dB
1 MHz to 10MHz	> 30 dB
Channel Crosstalk	
DC to 1 MHz	< -60 dB
1 MHz to 10 MHz	< -40 dB
Switching Voltage	
AC	250 V, Max
DC	110 V, Max
Switching Current	
AC	6 A, Max
DC	6 A, Max
Switching Power	
AC	1500 VA, Max
DC	180 W, Max
Path resistance	< 200 m Ω @ 6 A
Capacitance	
Channel-Chassis	< 450 pF
Open-Channel	< 150 pF
Insulation resistance	> 10 ⁹ Ω
Relay Settling Time	< 15 ms
Surge Withstand Voltage	> 1000 V DC
Shock	30g, 11 ms, ½ sine wave
Vibration	0.013 in. P-P, 5-55 Hz
Bench Handling	4 in., 45°
Temperature	
Operating	0°C to +55°C
Non-operating	-40°C to +75°C
Relative Humidity	85%, non-condensing at < 30°C

Altitude	
Operating	10,000 feet
Non-operating	15,000 feet
Power Requirements	
+5V	250mA (w/o Option-01T) 1.15A (w/ Option-01T)
+5V	40mA per energized relay
Cooling (25% Relays energized operating at full rated current)	
	5.1 Liters/sec @ 0.5 mmH ₂ O
Weight	
w/o Option-01T	3.3 lbs. (1.5 kg)
with Option-01T	3.6 lbs. (1.64 kg)
MTBF (MIL-HDBK-217-FN2 method)	
Excluding relays	1,500,000 hours
Including relays	435,000 hours
Relay Life Expectancy	
Mechanical	50,000,000 operations
Electrical	100,000 operations at full load
Dimensions (Module)	C-Size, Single Slot VXI bus Module

Power Dissipation

While the cooling of the 1260-16A is dependent upon the chassis into which it is installed, the module can normally dissipate approximately 80 W. Care must be taken, then, in the selection and loading of the plug-in modules used in the chassis. It is not possible to fully load the module, energize every relay, and run full power through every set of contacts, all at the same time. In practice this situation would never occur.

To properly evaluate the power dissipation of the plug-in modules, examine the path resistance, the current passing through the relay contacts, power to the coils, the ambient temperature, and the number of relays closed at any one time.

For example, if a 1260-16A module (containing 64 relays) has 16 relays closed, passing a current of 6 A, then:

$$\begin{aligned} \text{Total power dissipation} = & \\ & [(\text{current})^2 * (\text{path resistance}) * 16] + (\text{coil power} * 16) + \\ & (\text{quiescent power}) \end{aligned}$$

By substituting the actual values:

$$\begin{aligned} \text{Total power dissipation} &= \\ &[(6 \text{ A})^2 * (.100 \Omega) * 16] + [0.04\text{A} * 5\text{V} * 16] + (5.75 \text{ W}) \\ &= 66.55 \text{ W at } 55^\circ\text{C} \end{aligned}$$

This is acceptable power dissipation for an individual plug-in module. The overall module power dissipation is approximately 66.55W, which is well within the cooling available in any commercial VXIbus chassis. In practice, rarely are more than 25% of the module's relays energized simultaneously, and rarely is full rated current run through every path. In addition, the actual contact resistance is typically one-half to one-fourth the specified maximum, and temperatures are normally not at the rated maximum. The typical power dissipation for each module should be no more than 33.28W.

Most users of a signal-type switch, such as the 1260-16A, switch no more than a few hundred milliamperes and are able to energize all relays simultaneously, should they so desire.

Additionally, if fewer plug-in modules are used, more power may be dissipated by the remaining cards. By using a chassis with high cooling capacity, such as the 1261B, almost any configuration may be realized.

About MTBF

The 1260-16A MTBF is 1,500,000 hours, calculated in accordance with MIL-HDBK-217-FN2, with the exception of the electromechanical relays. Relays are excluded from this calculation because relay life is strongly dependent upon operating conditions. Factors affecting relay life expectancy are:

1. Switched voltage
2. Switched current
3. Switched power
4. Maximum switching capacity
5. Maximum rated carrying current
6. Load type (resistive, inductive, capacitive)
7. Switching repetition rate
8. Ambient temperature

For example, under a given condition of 6 A switched current, 1 cycles/hour switch rate, and 30°C ambient temperature, MTBF is calculated to be 435,000 hours.

The most important factor is the maximum switching capacity, which is an interrelationship of maximum switching power, maximum switching voltage and maximum switching current. When a relay operates at a lower percentage of its maximum switching capacity, its life expectancy is longer. The maximum switching capacity specification is based on a resistive load, and must be further de-rated for inductive and capacitive loads.

For more details about the above life expectancy factors, refer to the data sheet for the switch plug-in module.

The relay used on the 1260-16A plug-in is part no. 310288. The relay manufacturer's specifications for this relay are:

Life Expectancy		
Mechanical		50,000,000 operations
Electrical		100,000 operations at full rated load (resistive)

For additional relay specifications, refer to the relay manufacturer's data sheet.

Ordering Information

Listed below are part numbers for the 1260-16A switch module. The 1260-16A uses a single type of mating connector.

ITEM	DESCRIPTION	PART #
1260-16A Switch Module w/o – 01T	64 Channel, 6 A, 64 SPDT Power Switch Consists of: 1260-16A Assy. 1260-16A manual	408012 408031 980673-064
Option-01T	Option-01T (installed) Option-01T (spare) Instruction Manual for Option-01T (Must be added w/ Option-01T installed)	OPT-405108-001 407531-001 980806-999
1260-16A Mating Connector	50-pin mating connector shells	601855-050
Mating connector pins	200 mating connector solder type pins	601857
Additional Manual		980673-064

INSTALLATION INSTRUCTIONS

Unpacking and Inspection



1. Remove the 1260-16A module and inspect it for damage. If any damage is apparent, inform the carrier immediately. Retain shipping carton and packing material for the carrier's inspection.
2. Verify that the pieces in the package you received contain the correct 1260-16A module option and the 1260-16A Users Manual. Notify EADS North America Defense Test and Services, Inc. if the module appears damaged in any way. Do not attempt to install a damaged module into a VXI chassis.
3. The 1260-16A module is shipped in an anti-static bag to prevent electrostatic damage to the module. Do not remove the module from the anti-static bag unless it is in a static-controlled area.

Reshipment Instructions

1. Use the original packing when returning the switching module to EADS North America Defense Test and Services, Inc. for calibration or servicing. The original shipping carton and the instrument's plastic foam will provide the necessary support for safe reshipment.
2. If the original packing material is unavailable, wrap the switching module in an ESD Shielding bag and use plastic spray foam to surround and protect the instrument.
3. Reship in either the original or a new shipping carton.

Option 01T Installation

Installation of the Option 01T is described in the Installation and Setup section of the 1260A-Option 01T Users Manual, Publication No. 980806-999.

Module Installation

Installation of the 1260-16A Switching Module into a VXI mainframe, including the setting of switches SW3-1 through SW3-4, SW1, and SW2, is described in the Setup Section of the 1260A Option 01T Users Manual, Publication No. 980806-999. **Note that the designators of SW on 1260-16A are different from the Option 01T manual. SW3 on 1260-16A is the SW1 in Option 01T manual, SW2 and SW3 on 1260-16A are the SW1 and SW2 in Option 01T manual.**

Module Configuration

The 1260-16A is a 64-channel module consisting of 64 individual SPDT relay switches.

For a block diagram of the switches used on the 1260-16A, refer to **Figure 2-1**.

Figure 2-1, 1260-16A, Switch Block Diagram

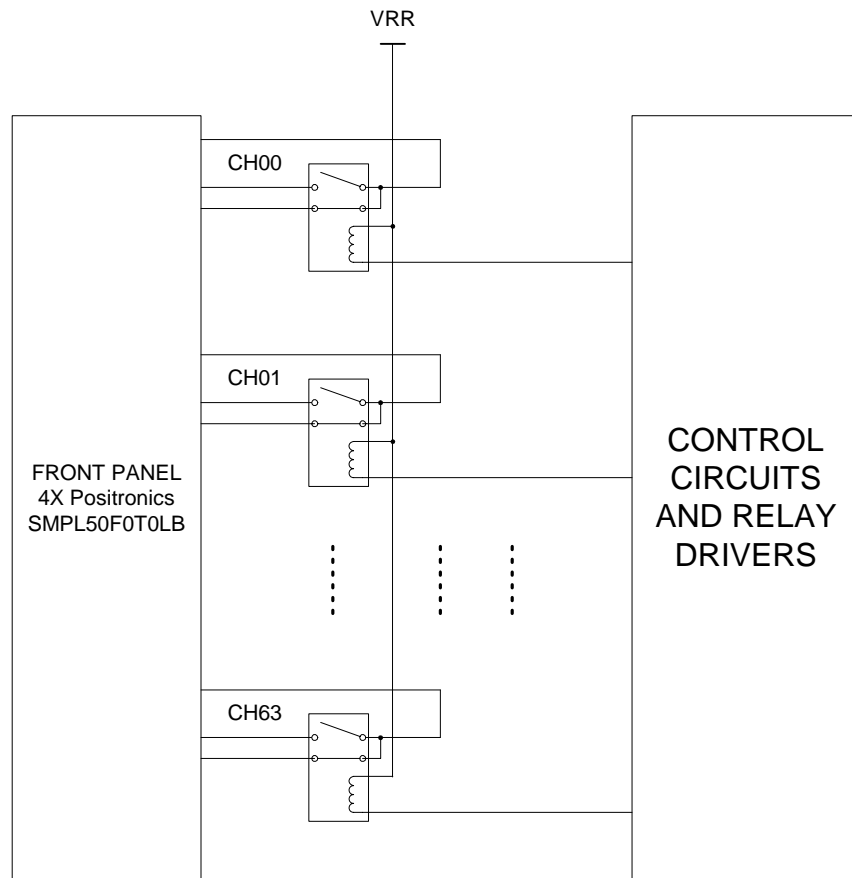

Front Panel Connectors

The 1260-16A has four 50-pin front-panel connectors, labeled J200, J201, J202 and J203. It has one pin for each input and two for outputs. See **Figure 2-2** and See **Figure 2-3** for pin numbering. **Table 2-1** shows the mapping of channel numbers to connector pins. Information about available mating connectors is provided in **Table 2-2**.

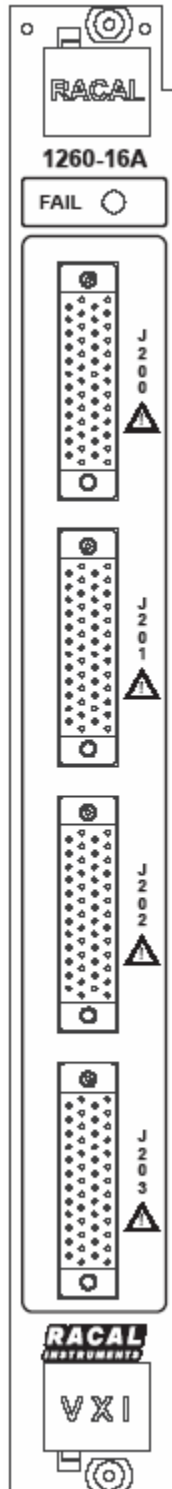

Figure 2-2, Front Panel Connector Numbering

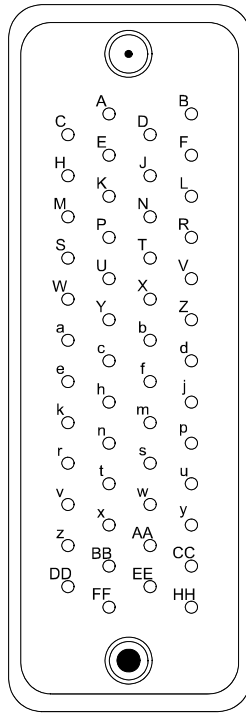

Figure 2-3, Front Panel Connector Pin Numbering

Table 2-1, 1260-16A Front-Panel Connections

Channel NO.	COM	NC	NO
00	J200-A	J200-C	J200-D
01	J200-E	J200-H	J200-K
02	J200-F	J200-J	J200-L
03	J200-M	J200-P	J200-S
04	J200-N	J200-R	J200-T
05	J200-U	J200-W	J200-Y
06	J200-V	J200-X	J200-Z
07	J200-a	J200-c	J200-e
08	J200-b	J200-d	J200-f
09	J200-h	J200-k	J200-n
10	J200-j	J200-m	J200-p
11	J200-r	J200-t	J200-v
12	J200-s	J200-u	J200-w
13	J200-x	J200-z	J200-BB
14	J200-y	J200-AA	J200-CC
15	J200-DD	J200-EE	J200-FF
16	J201-A	J201-C	J201-D
17	J201-E	J201-H	J201-K
18	J201-F	J201-J	J201-L
19	J201-M	J201-P	J201-S
20	J201-N	J201-R	J201-T
21	J201-U	J201-W	J201-Y
22	J201-V	J201-X	J201-Z
23	J201-a	J201-c	J201-e
24	J201-b	J201-d	J201-f
25	J201-h	J201-k	J201-n
26	J201-j	J201-m	J201-p
27	J201-r	J201-t	J201-v
28	J201-s	J201-u	J201-w
29	J201-x	J201-z	J201-BB
30	J201-y	J201-AA	J201-CC
31	J201-DD	J201-EE	J201-FF
32	J202-A	J202-C	J202-D
33	J202-E	J202-H	J202-K
34	J202-F	J202-J	J202-L
35	J202-M	J202-P	J202-S
36	J202-N	J202-R	J202-T
37	J202-U	J202-W	J202-Y
38	J202-V	J202-X	J202-Z
39	J202-a	J202-c	J202-e
40	J202-b	J202-d	J202-f
41	J202-h	J202-k	J202-n
42	J202-j	J202-m	J202-p
43	J202-r	J202-t	J202-v
44	J202-s	J202-u	J202-w
45	J202-x	J202-z	J202-BB
46	J202-y	J202-AA	J202-CC
47	J202-DD	J202-EE	J202-FF
48	J203-A	J203-C	J203-D
49	J203-E	J203-H	J203-K
50	J203-F	J203-J	J203-L
51	J203-M	J203-P	J203-S
52	J203-N	J203-R	J203-T
53	J203-U	J203-W	J203-Y
54	J203-V	J203-X	J203-Z
55	J203-a	J203-c	J203-e
56	J203-b	J203-d	J203-f

57	J203-h	J203-k	J203-n
58	J203-j	J203-m	J203-p
59	J203-r	J203-t	J203-v
60	J203-s	J203-u	J203-w
61	J203-x	J203-z	J203-BB
62	J203-y	J203-AA	J203-CC
63	J203-DD	J203-EE	J203-FF

Mating Connectors

Mating connector accessories are available from Positronic:

The cable assembly should be made from at least 22 AWG wire. The mating contacts are solder style and can handle wire up to 22 AWG.

After wire attachment, the pin is inserted in the housing and will snap into place, providing positive retention. To ensure that the pin is locked into place, the assembler should pull on the wire after insertion.

Refer to **Table 2-1** for channel-to-pin mapping information. **Table 2-2** contains manufacture's part numbers for the connector housing and contacts.

Table 2-2, Mating Connectors and Pins

Manufacturer	Mfr. P/N	Description
Racal	601855-050	1260-16A Mating Connector Body
Racal	601857	1260-16A Mating Connector Pin
Positronic	SGMC50M0E100J0	Connector block, 50-position. Mates with front-panel connector. Pins sold separately.
Positronic	MS422N	Male contact, solder cup type, for up to 22 AWG wire. Mates with front-panel connector pins. Low resistance contacts.

More About Maximum Current Ratings

The front panel connector and pins are rated for 6 A per pin, with all channels conducting full-rated current. The relays are rated at 6A. This keeps the temperature rise within 30°C. It should be noted that with all electromechanical relays, the higher the switched power (voltage times current), the shorter the useful life of the relays.

Definitions:

- *Max current carrying capacity*

The maximum current that the relay can conduct if the relay is not switched while voltage is applied. The maximum current carrying capacity is affected by the size of the conducting section of the contact at its smallest area. The listed values are obtained from several tests in laboratories under room-temperature conditions (21°C). The contact is considered to be in free air. The maximum current carrying for the 1260-16A is 6A.

- *Max operating current*

The current the contacts can switch while conducting, without deteriorating. This depends on working conditions, such as dissipated heat, cooling provisions, ambient temperature, insulation material, etc. The maximum operating current for the 1260-16A is 6A.

- *Recommended continuous current*

The maximum current recommended for indefinitely-long time periods. The primary concern here is the heat generated in the relay. This specification can be applied for normal working conditions. The specification includes a safety margin. However, there are restrictions in the application of the given values. The most important restriction is the cross-sectional area of the connecting wire, insulation temperature range, and wire bundling. The recommended continuous current for the 1260-16A is 6A.

Installation

To install the 1260-16A Switching Module into a VXI mainframe chassis, engage the printed circuit board into the grooves of the desired chassis slot. Slide the 1260-16A into the chassis until its connector mates with the connector on the chassis backplane. Push firmly to fully seat the connector. Tighten the two retaining screws at the top and bottom of the 1260-16A module.

Chapter 3

MODULE OPERATION

Operating Modes

The 1260-16A may be operated either in *message-based* mode or in *register-based* mode.

In the *message-based* mode, the 1260-01T switch controller interprets commands sent by the slot 0 controller, and determines the appropriate data to send to the control registers of the 1260-16A module.

A conceptual view of the message-based mode of operation is shown in **Figure 3-1** below.

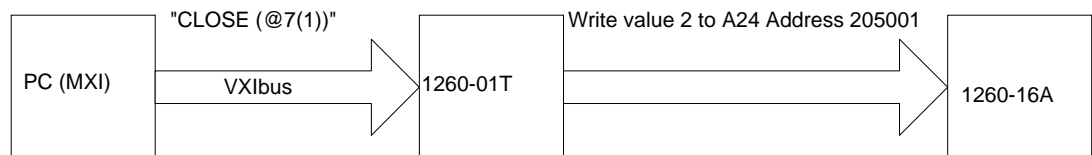

Figure 3-1, Message-Based Mode of Operation

In the *register-based* mode, the user writes directly to the control registers on the 1260-16A module. The 1260-01T command module does not monitor these operations, and does not keep track of the relay states on the 1260-16A module in this mode.

A conceptual view of the register-based mode is shown in **Figure 3-2** below.

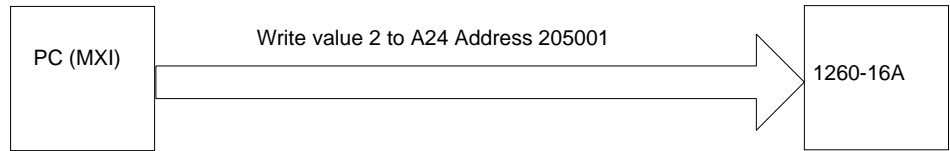

Figure 3-2, Register-Based Mode of Operation

Since the 1260-01T switch controller does not keep track of relay states during the register-based mode, it is advisable to use **either** the message-based or the register-based mode, and continue to use the same mode throughout the application program.

In general, the message-based mode of operation is easier to use with utility software such as the National Instruments VXI Interactive Control (VIC) program. The message-based mode allows the user to send ASCII text commands to the 1260-01T and to read replies from the 1260-01T. In addition, some features, such as the SCAN list, are available only in the message-based mode of operation.

The register-based mode provides faster control of relay channels. In this mode, relay operations are processed in less than 9 microseconds, not counting relay settling time or software overhead inherent in I/O libraries such as VISA. To determine the relay settling time, refer to Relay Settling Time in the Specifications section.

Consult the 1260-01T User's Manual for a comparison of the message-based and register-based modes of operation.

Operating In Message-Based Mode

Channel Descriptors For 1260-16A

The standard 1260-01T commands are used to operate the 1260-16A module. These commands are described in the 1260-01T User's Manual.

The Module Specific Syntax for the 1260-16A module is as follows:

<module address>.<channel>

where

<module address> is the switch card address. The module address is a number from 1 through 12, inclusive. It can be set by the logical address DIP switch SW3 on the 1260-16A.

<channel> is the channel number to be switched; the range of values for <channel> is 00 to 63.

Set the module addresses for the 1260-16A and other 1260-Series modules so that no address is used by more than one 1260-Series module. For instructions on setting module addresses for a 1260-Series module, see the label on the side panel of the module.

Example:

For switch card address 9; channel 2

CLOSE 9.02

OPEN 9.02

Note that channels remain closed until opened by an OPEN command, RESET command, VXI hand or soft reset, or power-off.

Reply To The MOD:LIST? Command

The 1260-01T returns a reply to the MOD:LIST? command. This reply is unique for each different 1260 series switch module. The syntax for the reply is:

```
<module address> : <module-specific identification string>
```

The <module-specific identification string> for the 1260-16A is:

```
1260-16A 64 CHANNEL SPDT 6 AMP RELAY MODULE
```

So, for a 1260-16A whose <module address> is set to 6, the reply to this query would be:

```
6 : 1260-16A 64 CHANNEL SPDT 6 AMP RELAY MODULE
```

Operating The 1260-16A in Register-Based Mode

In register-based mode, the 1260-16A is operated by directly writing to control registers and reading from status registers on the 1260-16A module. There are 8 control registers and 8 status registers on the 1260-16A module. Refer to **Table 3-1** for the register bit map. When a control register is written to, all channels controlled by that register are operated simultaneously. Writing a '1' to the register bit will activate the relay coil and put it into the NO position. Writing a '0' to the register bit will deactivate the relay coil and put it back into the NC position. Default value for all control registers is hex '00' after reset.

The status registers contain the Read Back bits from the coil voltage. Refer to **Table 3-2** for the status register bit map.

The Read Back status reads the coil value for each relay inverted. When the relay coil is deactivated by setting the relay control bit to '0' (switch is in the Normally Closed position) the Read Back bit is '0'. When the relay coil is activated by setting the relay control bit to '1' (switch is in the Normally Open position) the Read Back bit is '1'.

The control registers are located in the VXI bus A24 Address Space. The A24 address for a control register depends on:

1. The A24 Address Offset assigned to the 1260-01T module by the Resource Manager program. The Resource Manager program is provided by the VXI bus slot-0 controller vendor. The A24 Address Offset is placed into the "Offset Register" of the 1260-01T by the Resource Manager.

2. The <module address> of the 1260-16A module. This is a value in the range 1 through 12.
3. Each control register/status register on the 1260-16A has a unique address.

The base A24 address for the 1260-16A module may be calculated by:

$$(A24 \text{ Offset of Option-01T}) + (1024 \times \text{Module Address of 1260-16A}).$$

The A24 address offset is usually expressed in hexadecimal. A typical value of 204000_{16} is used in the examples that follow.

A 1260-16A with a module address of 6 would have the base A24 address computed as follows:

$$\begin{aligned} \text{Base A24 Address of 1260-16A} &= 204000_{16} + (400_{16} \times 6_{10}) \\ &= 205800_{16} \end{aligned}$$

The control registers for 1260-Series VXI modules are always on odd-numbered A24 addresses. The two control registers for the 1260-16A reside at the first two odd-numbered A24 addresses for the module:

$$(\text{Base A24 Address of 1260-16A}) + 1 = \text{Control Reg. 0}$$

$$(\text{Base A24 Address of 1260-16A}) + 3 = \text{Control Reg. 1}$$

So, for our example, the two control registers are located at:

205801 Control Register 0

205803 Control Register 1

Refer to **Figure 3-3** for 1X2 channel nomenclature.

Table 3-1 shows the channel assignments for each control register while **Table 3-2** shows the channel assignments for each status register.

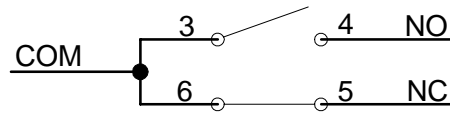

Figure 3-3, Relay Diagram

Table 3-1, Control Register Channel Assignments

Control Register	Channels							
	Bit 7 (MSB)	Bit 6	Bit 5	Bit 4	Bit 3	Bit 2	Bit 1	Bit 0 (LSB)
0	CH07 Relay 8	CH06 Relay 7	CH05 Relay 6	CH04 Relay 5	CH03 Relay 4	CH02 Relay 3	CH01 Relay 2	CH00 Relay 1
1	CH15 Relay 16	CH14 Relay 15	CH13 Relay 14	CH12 Relay 13	CH11 Relay 12	CH10 Relay 11	CH09 Relay 10	CH08 Relay 9
2	CH23 Relay 24	CH22 Relay 23	CH21 Relay 22	CH20 Relay 21	CH19 Relay 20	CH18 Relay 19	CH17 Relay 18	CH16 Relay 17
3	CH31 Relay 32	CH30 Relay 31	CH29 Relay 30	CH28 Relay 29	CH27 Relay 28	CH26 Relay 27	CH25 Relay 26	CH24 Relay 25
4	CH39 Relay 40	CH38 Relay 39	CH37 Relay 38	CH36 Relay 37	CH35 Relay 36	CH34 Relay 35	CH33 Relay 34	CH32 Relay 33
5	CH47 Relay 48	CH46 Relay 47	CH45 Relay 46	CH44 Relay 45	CH43 Relay 44	CH42 Relay 43	CH41 Relay 42	CH40 Relay 41
6	CH55 Relay 56	CH54 Relay 55	CH53 Relay 54	CH52 Relay 53	CH51 Relay 52	CH50 Relay 51	CH49 Relay 50	CH48 Relay 49
7	CH63 Relay 64	CH62 Relay 63	CH61 Relay 62	CH60 Relay 61	CH59 Relay 60	CH58 Relay 59	CH57 Relay 58	C56 Relay 57

Table 3-2, Status Register Channel Assignments

Control Register	Channels							
	Bit 7 (MSB)	Bit 6	Bit 5	Bit 4	Bit 3	Bit 2	Bit 1	Bit 0 (LSB)
0	CH07 Relay 8	CH06 Relay 7	CH05 Relay 6	CH04 Relay 5	CH03 Relay 4	CH02 Relay 3	CH01 Relay 2	CH00 Relay 1
1	CH15 Relay 16	CH14 Relay 15	CH13 Relay 14	CH12 Relay 13	CH11 Relay 12	CH10 Relay 11	CH09 Relay 10	CH08 Relay 9
2	CH23 Relay 24	CH22 Relay 23	CH21 Relay 22	CH20 Relay 21	CH19 Relay 20	CH18 Relay 19	CH17 Relay 18	CH16 Relay 17
3	CH31 Relay 32	CH30 Relay 31	CH29 Relay 30	CH28 Relay 29	CH27 Relay 28	CH26 Relay 27	CH25 Relay 26	CH24 Relay 25
4	CH39 Relay 40	CH38 Relay 39	CH37 Relay 38	CH36 Relay 37	CH35 Relay 36	CH34 Relay 35	CH33 Relay 34	CH32 Relay 33
5	CH47 Relay 48	CH46 Relay 47	CH45 Relay 46	CH44 Relay 45	CH43 Relay 44	CH42 Relay 43	CH41 Relay 42	CH40 Relay 41
6	CH55 Relay 56	CH54 Relay 55	CH53 Relay 54	CH52 Relay 53	CH51 Relay 52	CH50 Relay 51	CH49 Relay 50	CH48 Relay 49
7	CH63 Relay 64	CH62 Relay 63	CH61 Relay 62	CH60 Relay 61	CH59 Relay 60	CH58 Relay 59	CH57 Relay 58	C56 Relay 57

This page was left intentionally blank.

Chapter 4

PRODUCT SUPPORT

Product Support

EADS North America Defense Test and Services, Inc. has a complete Service and Parts Department. If you need technical assistance or should it be necessary to return your product for repair or calibration, call 1-800-722-3262. If parts are required to repair the product at your facility, call 1-949-859-8999 and ask for the Parts Department.

When sending your instrument in for repair, complete the form in the back of this manual.

For worldwide support and the office closest to your facility, refer to the website for the most complete information <http://www.eads-nadefense.com>.

Warranty

Use the original packing material when returning the 1260-16A to EADS North America Defense Test and Services, Inc. for calibration or servicing. The original shipping container and associated packaging material will provide the necessary protection for safe reshipment.

If the original packing material is unavailable, contact EADS North America Defense Test and Services, Inc. Customer Service at 1-800-722-3262 for information.

REPAIR AND CALIBRATION REQUEST FORM

To allow us to better understand your repair requests, we suggest you use the following outline when calling and include a copy with your instrument to be sent to the EADS North America Defense Test and Service, Inc. Repair Facility.

Model _____ Serial No. _____ Date _____

Company Name _____ Purchase Order # _____

Billing Address _____

City

State/Province

Zip/Postal Code

Country

Shipping Address _____

City

State/Province

Zip/Postal Code

Country

Technical Contact _____ Phone Number () _____

Purchasing Contact _____ Phone Number () _____

1. Describe, in detail, the problem and symptoms you are having. Please include all set up details, such as input/output levels, frequencies, waveform details, etc.

2. If problem is occurring when unit is in remote, please list the program strings used and the controller type.

3. Please give any additional information you feel would be beneficial in facilitating a faster repair time (i.e., modifications, etc.)

4. Is calibration data required? Yes No (please circle one)

Call before shipping
 Note: We do not accept
 "collect" shipments.

Ship instruments to nearest support office.